

A functionally graded titanium/hydroxyapatite film obtained by sputtering

KAZUhide OZEKI*, TOSHIO YUHTA, YASUHIRO FUKUI

*Applied Systems Engineering, Graduate School of Science and Engineering,
Tokyo Denki University, Ishizaka, Hatoyama, Hiki, Saitama, 350-0394, Japan*

HIDEKI AOKI

*Frontier Research and Development Center, Tokyo Denki University, Ishizaka, Hatoyama,
Hiki, Saitama, 350-0394, Japan*

IKUYA NISHIMURA

*Department of Biomedical Engineering, Hokkaido University, Kita-13 Nishi-8, Kita-ku,
Sapporo, 060-8628, Japan*

E-mail: ozeki@bme.f.dendai.ac.jp

A functionally graded film of titanium/hydroxyapatite (HA) was prepared on a titanium substrate using a radio frequency magnetron sputtering. The ratio of titanium to HA was controlled by moving the target shutter. The film was composed of five layers, with overall film thickness of 1 μm . The HA was concentrated close to the surface, while the titanium concentration increased with proximity to the substrate. The bonding strength between the film and the substrate was 15.2 MPa in a pull-out test and the critical load from a scratch test was 58.85 mN. The corresponding values of a pure HA sputtered film were 8.0 MPa and 38.47 mN, respectively. The bonding strength of a pure HA plasma spray coating was 10.4 MPa in the pull-out test. The graded film and the pure HA film were sputter-coated to a thickness of 1 μm on titanium columns (10 mm in length and 4 mm in diameter). These columns were implanted in diaphyses of the femora of six adult dogs and a push-out test was carried out after 2, 4, and 12 weeks. After 12 weeks, the push-out strengths of the graded film, the pure HA film and the non-coated columns were 3.7, 3.5, and 1.0 MPa.

© 2002 Kluwer Academic Publishers

1. Introduction

A functionally graded material (FGM) is composed of a continuously graded zone that does not possess the clear interface of a usual composite material. The FGM concept is used in various fields such as aerospace, nuclear fusion, electronics, and medicine [1–3]. F. Watari *et al.* [4–6] applied the FGM concept to dental implants made of titanium and hydroxyapatite (HA). They pressed titanium and HA powders in a mold (3 mm in diameter and 10 mm in length) at a pressure of 1000 MPa and then sintered the preform at 1300 °C in a vacuum chamber. The distribution of the titanium and HA powders gradually changed from titanium to HA. Pure titanium columns and 80%-titanium/20%-HA graded columns have been implanted in the mandibles of rabbits, and it was concluded from the histological results that new bone was formed more directly and tightly when in contact with the graded columns than when in contact with pure titanium columns.

There have been few reports regarding FGMs fabricated using sputtering techniques. Sputtering techniques allow control of film thickness below 1 μm [7, 8].

In 1992, the present authors studied sputtered FGMs [9]. In 1999, H. Leiste *et al.* prepared a graded film using divided targets consisting of TiC and TiN. The graded film was deposited by moving the substrate below the targets during deposition from the carbide-rich to the nitride-rich forms. From the composition distribution of the film, the carbide continuously increased with depth and the nitride decreased. It was not possible to control deposition so as to produce either pure TiC on the substrate, or pure TiN at the surface [10].

In the present study using the sputtering technique, a functionally graded film (FGF) of titanium/HA was prepared by shifting the target shutter above the powder target, which was divided into titanium and HA. The shutter covered only the chosen target segment, and it was expected to allow the deposition of pure HA, or pure titanium, at the surface or the substrate side of the film, respectively. The FGF was composed of five layers, and the constituent component gradually changed from the titanium of the substrate to HA at the film surface by five steps.

*Author to whom all correspondence should be addressed.

2. Materials and method

2.1. Materials

The substrates used were titanium plates ($20\text{ mm}^2 \times 1\text{ mm}$) and titanium columns (10 mm in length and 4 mm in diameter). The HA was prepared by a wet method and heated at $800\text{--}900^\circ\text{C}$. The particle size used for sputtering was $2\text{--}10\ \mu\text{m}$ and for plasma spraying, below $200\ \mu\text{m}$. Titanium powder with $30\text{--}50\ \mu\text{m}$ particle size was prepared for use in sputtering.

2.2. Method

2.2.1. Preparation of the coating

A radio frequency magnetron sputter-coating was carried out using 400 W discharge power and 5 Pa Ar gas pressure using a SPF-210HS (Anelva Corp.). Before the coating process, the substrates were ultrasonically cleaned in acetone for 10 min to remove any contamination.

To prepare the FGF, the quantity of titanium and HA in the film was controlled by moving the target shutter (see Fig. 1). In the first deposition, the exposed titanium sputtering area was 100%, then the area was systematically decreased to 70%, 50%, 30%, and 0% by the final deposition (when the exposed HA area was 100%) as described in Table I. The film was composed of five layers, with each layer being $0.2\ \mu\text{m}$ thick.

In the plasma spray coating process, a titanium substrate was sand-blasted using 60 SiC abrasive prior to coating and then the HA was coated on the titanium substrate using a 35 kW plasma spray gun (Meteko Corp., 7-M). The coating thickness obtained was $40\text{--}60\ \mu\text{m}$ thick.

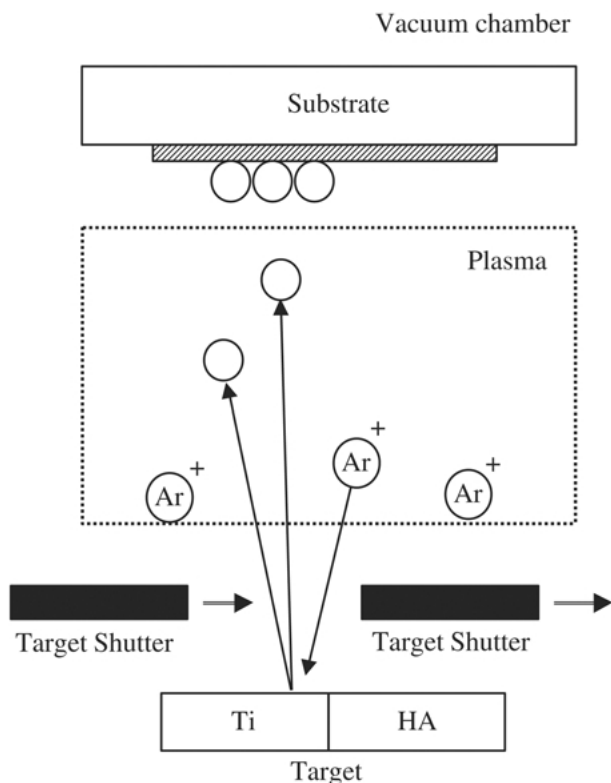

Figure 1 Schematic drawing of the sputtering chamber.

TABLE I Deposition rate dependence on ratio of sputtering area

Layer no.	Ratio of sputtering area (%)		Deposition rate (μm)
	Ti	HA	
1	100	0	1.00
2	70	30	0.80
3	50	50	0.62
4	30	70	0.32
5	0	100	0.26

Layer no. 1 = the substrate side, layer no. 5 = the surface side.

2.2.2. XPS and XRD of the titanium/HA FGF

The X-ray photoelectron intensities of the elements Ca, P, and Ti in each of the five layers were measured using an X-ray photoelectron spectroscopy (XPS, Vacuum Generator Co., Ltd.; ESCA-III) with $\text{MgK}\alpha$ radiation. The weight ratio of titanium and HA in each layer was calculated from a calibration curve of the intensity vs. weight ratios.

After sputter-coating, the film was heated at 800°C in air for 1 h to allow for crystallization. The crystal structures of the FGF and the annealed FGF were identified using X-ray diffractometry (XRD; Rigaku Corp.; Geiger-flex3053) with $\text{CuK}\alpha$ radiation at 35 kV and 20 mA excitation current.

2.2.3. Mechanical tests

A pull-out and a scratch test were used to measure the bonding strength between the coating and the substrate.

In the pull-out test, 4-mm diameter aluminum columns were glued to the FGF, the pure HA film and the plasma spray coating using an epoxy resin adhesive (Sumitomo 3M Ltd.; SW2214), and the samples set on a jig, as illustrated in Fig. 2. The columns were pulled from each coating at a crosshead speed of $0.5\ \text{mm/min}$ using an

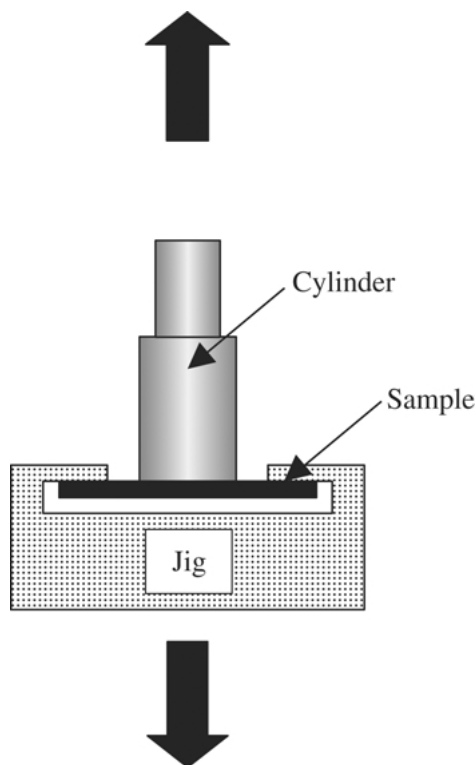

Figure 2 Schematic drawing of the pull-out test.

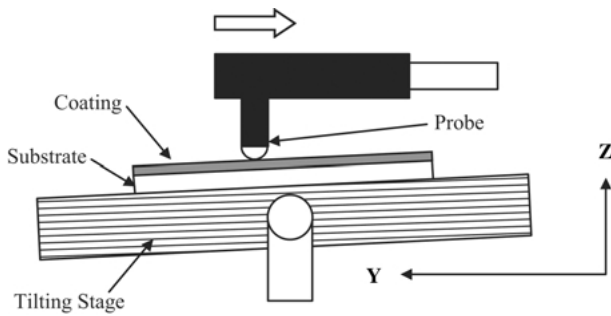

Figure 3 Schematic drawing of the scratch test.

Instron universal testing instrument (Instron Corp.; Model 1130). The strength was calculated by dividing the pull-out force by the contact area. The strength was obtained from an average of 10 tests.

The scratch test on the FGF and the pure HA film was performed using an ultra-fine film scratch tester (Rhesca Co., Ltd.; CSR-02). A spherical stylus scratched the film and the frictional force signal of the stylus pressed on the film increased with the load. The load at which the film is stripped from the substrate is termed the critical load, and corresponds to the bonding strength of the film (Fig. 3). The bonding strength obtained by this method is expressed as a force unit. The shear bonding strength can then be calculated using the equation of Benjamin and Weaver [11].

$$F = \frac{H_B}{\sqrt{(\pi H_B / W_c) R^2 - 1}}$$

where F is the shear bonding strength, H_B is the Brinell hardness of the substrate, W_c is the critical load, and R is the radius of the stylus. The test was carried out at a stage angle of 5° , a load rate of 85.74 mN/mm and a stage speed of $5 \mu\text{m/s}$.

2.2.4. Animal tests

Six adult dogs weighing 8–13 kg were used for measuring the bone bonding strength using the push-out test. Under anesthesia, three 4-mm diameter holes were drilled into a diaphysis of the femur. A total of 27 columns were implanted in the holes, including nine coated with the FGF, nine coated with pure HA and nine non-coated columns.

Each column was removed after a defined period, shaped for the push-out test, and was set on a jig, as shown in Fig. 4. The columns were pushed out at a cross-head speed of 0.5 mm/min by the Instron universal testing instrument. The shear strength at the bone/column interface was calculated by dividing the push-out force by the contact area of the bone/column interface. The strength was obtained by averaging tests taken three times during each week.

After the mechanical tests, the columns were fixed using a 10% formalin solution for histological observation. The specimens were embedded in methyl-methacrylate without decalcifying, and were cut in the direction of the long axis of the column. They were then stained with toluidine blue for inspection using an optical microscope.

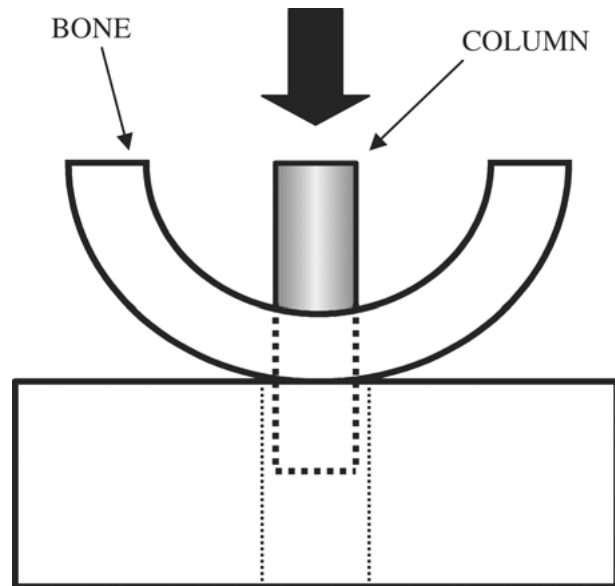

Figure 4 Schematic drawing of the push-out test.

3. Results

3.1. XPS and XRD of the titanium/Ha FGF

Fig. 5 shows the results of the XPS data from each layer. The concentration of titanium was strongest at the substrate side and then decreased towards the surface, while the HA concentration correspondingly increased. The titanium and HA concentrations at the surface of the film were about 40% and 60%, respectively.

Fig. 6 shows the XRD patterns of the FGF and the annealed FGF samples. In Fig. 6(a), a large broad peak was observed at around $2\theta = 31^\circ$, corresponding to non-crystalline HA, and two strong titanium peaks were observed at $2\theta = 38.4^\circ$ and 40.1° . After annealing, CaTiO_3 peaks preferentially appeared, and the peaks arising from CaO and HA can be seen in Fig. 6(b). From these results, it can be considered that any non-crystalline HA and CaO were crystallized after annealing, and that the FGF was consequently composed of HA, CaO, and titanium.

3.2. Bonding strength of the coating on the substrate

The bonding strengths of the FGF, the pure HA film, and the plasma spray coating from the pull-out test were 15.2, 8.0, and 10.4 MPa, respectively (Fig. 7).

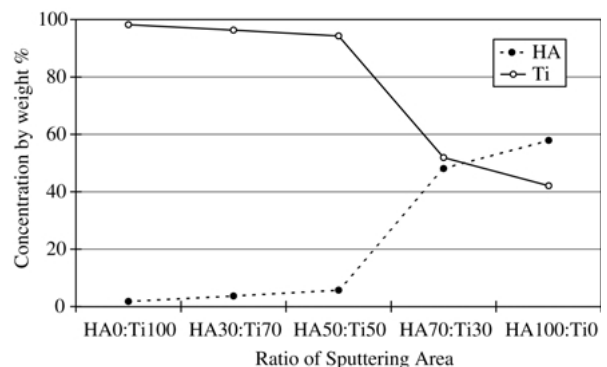

Figure 5 Concentration of HA and titanium by weight in each FGF layer by XPS.

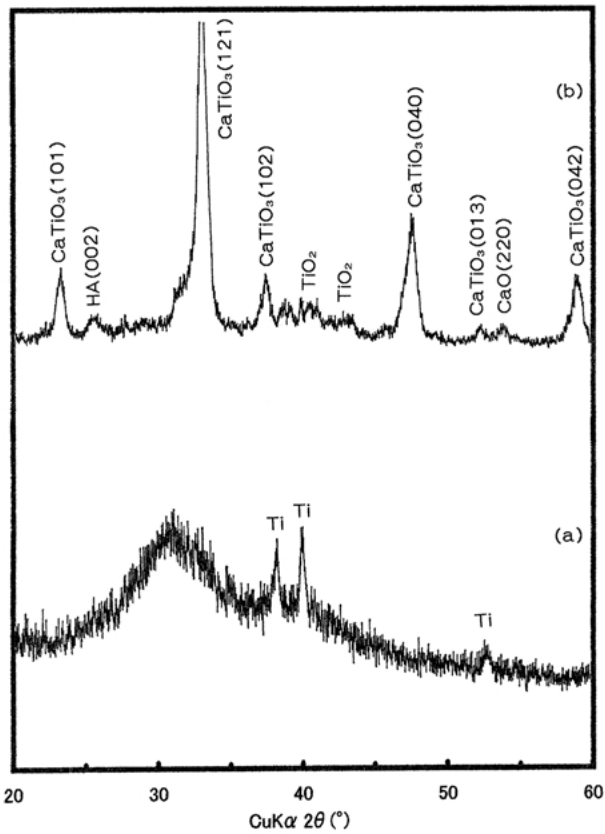

Figure 6 XRD patterns: (a) FGF, (b) FGF annealed at 800°C for 1 h.

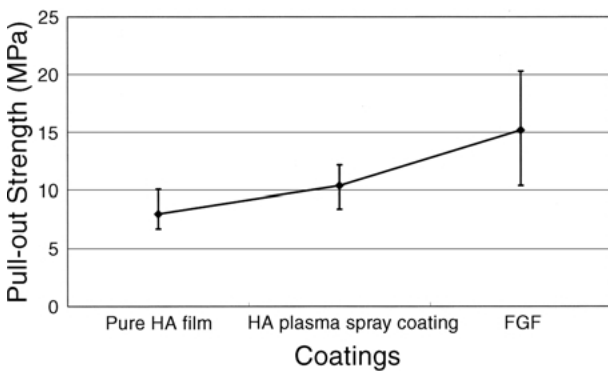

Figure 7 Bonding strength of various coatings from the pull-out test ($n = 10$).

Fig. 8 shows the scratching data and the scratch channel of the FGF, and Fig. 9 shows those of the pure HA film. In the scratch data, the transverse axis indicates the frictional signal. The critical load was 58.85 mN for the FGF (Fig. 8(a)) and 38.47 mN for the pure HA film (Fig. 9(a)). The shear bonding strengths were calculated as 1.5 and 1.0 GPa, using the equation of Benjamin and Weaver.

3.3. Bone bonding strength

Fig. 10 shows the push-out force related to the bone bonding strength. The strengths calculated from the force of the FGF after two and 12 weeks were 2.1 and 3.7 MPa, respectively, and those of the pure HA films as 2.0 and 3.5 MPa. On the other hand, the values of the non-coated samples were 0.4 and 1.0 MPa. The bone bonding strengths of the FGF were higher than those of non-coated samples.

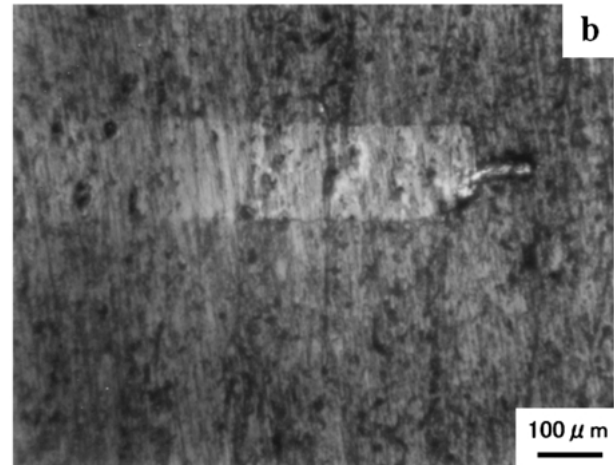
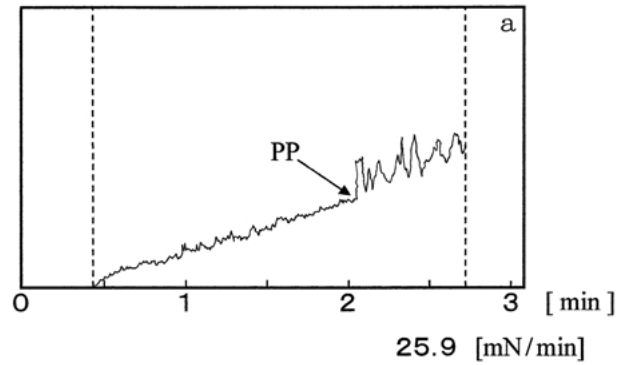

Figure 8 Result of the scratch test on the FGF: (a) scratch data; (b) scratch channel; (PP) peeling point.

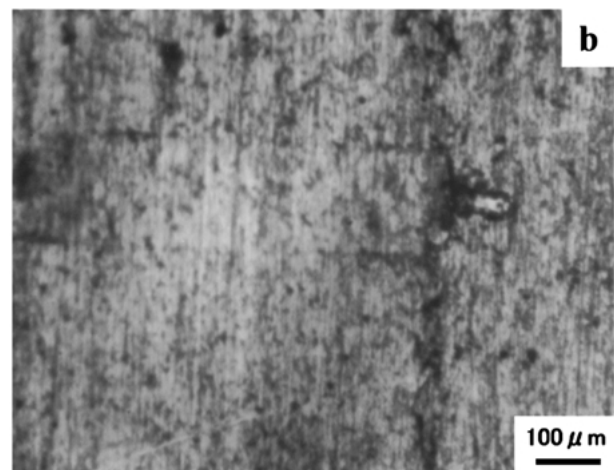
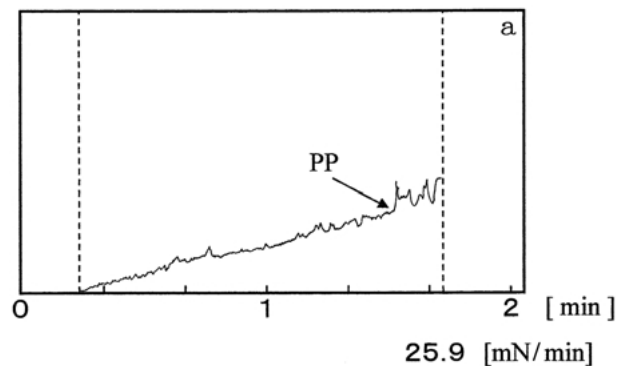

Figure 9 Result of the scratch test on the pure HA film: (a) scratch data; (b) scratch channel; (PP) peeling point.

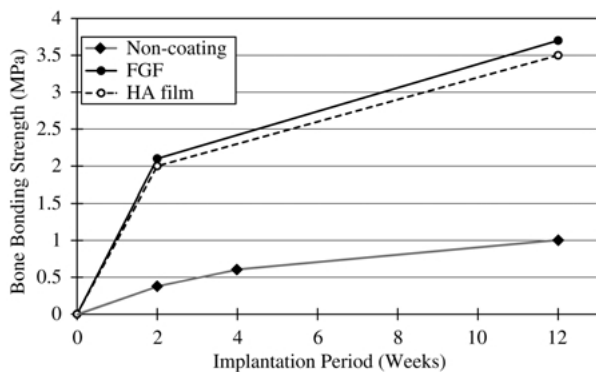

Figure 10 Bone bonding strength of various coating techniques during implantation period ($n=3$).

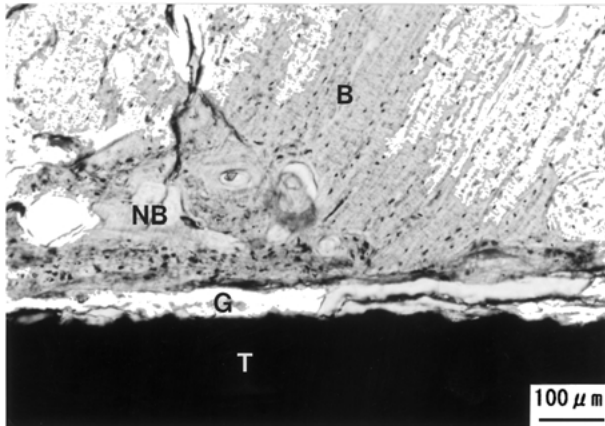

Figure 11 Undecalcified histological section of FGF after four weeks, (T) titanium, (G) gap, (B) bone, (NB) new bone.

Fig. 11 shows the histology of the FGF column after four weeks. In both the FGF and the pure HA film columns, gaps were seen at the interface of the bone/column after the push-out test. New bone formation was observed in all the periods, with no sign of inflammation.

4. Discussion

There have been a few reports on the preparation of FGMs by the sputtering technique. In the present paper, an FGM was prepared with HA and titanium by moving the sputter target shutter. From the FGF XPS results, the titanium concentration increased with depth, while the HA concentration decreased. The titanium concentration was over 40% at the surface of the film, while the HA showed a low concentration. This could be ascribed to the leakage of sputtered particles from around the edge of the shutter, and to a higher deposition rate of titanium relative to that of the HA. Hence, the titanium was highly concentrated in the surface layer of the film. The deposition rate of titanium was $1.0 \mu\text{m/h}$, while that of HA was $0.26 \mu\text{m/h}$. The higher sputtering rate for titanium indicates that it has a lower bonding energy than HA. Titanium and HA are composed from metallic and ionic bonds, respectively, and the Ti–Ti bonding energy is below 58 kcal mol^{-1} , while the Ca–O, P–O, and O–H bonding energies in HA are 110, 142.3, and $102.3 \text{ kcal mol}^{-1}$, respectively [3]. To prevent any

titanium contamination on the surface, it would seem necessary to modify the shutter design by extending the area of the target shutter.

The bonding strength between the film and the substrates was measured by pull-out and scratch tests. The values of the FGF, the pure HA film and the plasma spray coating were 15.2, 8.0, and 10.4 MPa in the pull-out test, and the shear strengths of the FGF and the pure HA film were calculated as 1.5 and 1.0 GPa from the scratch test. In each test, the FGF value was around 1.5 times higher than the pure HA film value. The values in the scratch test were around 100 times those of the pull-out test. Explanation of the difference, and the correlation, between these test values has not been clarified as yet, and there is much uncertainty about issues in the scratch mechanism. The bonding strength of the FGF was higher than for the other coatings in both of the mechanical tests. It is considered that the higher bonding strength can be attributed to the metallic bond of titanium between layers in the FGF.

In the animal tests, the bonding strengths of the FGF columns were 2.1 MPa after two weeks and 3.7 MPa after 12 weeks, which were stronger than the corresponding values of 0.4 and 1.0 MPa, respectively, for the non-coated samples. As the results of the XRD indicated, the FGF included HA particles. The FGF would therefore induce new bone formation more easily than the non-coated samples in light of the existence of the HA in the FGF [12–14].

5. Conclusions

1. A titanium/HA FGF was prepared using a sputtering technique with a moving target shutter.
2. The bonding strengths of the FGF, the pure HA film and the plasma spray coating were 15.2, 8.0, and 10.4 MPa in the pull-out test, while in the scratch test, the critical loads of the FGF and the pure HA film were shown to be 58.85 and 38.47 mN, respectively.
3. The bone bonding strength of the FGF was 3.7 MPa against 1.0 MPa for the non-coated film, and showed no significant difference from the pure HA film (3.5 MPa) after 12 weeks.

From these results, a functionally graded titanium/HA film can be conveniently prepared by moving a target shutter and using two types of source powder: titanium and HA. The FGF may be available for composite biomaterials under heavy loading conditions, such as in a hip joint or a tooth root.

Acknowledgments

The authors thank Prof. Y. Mitamura and Assoc. Prof. T. Shimooka (Hokkaido University Japan) for their surgical skills.

References

1. Practical New Material Association, ‘‘Practical New Material Technology Handbook’’ (TSC Publisher Co., Ltd. Tokyo) (1996) 123–129.

2. M. NIINO and S. MAEDA, *J. Functional Material* Tokyo, January (1990) 22–28.
3. Society of Applied Physics, “Thin Film Fabrication Handbook” (Kyoritsu Publishing Co., Ltd., Tokyo, 1991).
4. F. WATARI, A. YOKOYAMA, F. SASO, M. UO and T. KAWASAKI, “Proceedings of the 3rd International Symposium On Structural and Functional Gradient Materials” (1995) 1–6.
5. F. SASO, A. YOKOYAMA, F. WATARI and T. KAWASAKI, *Hokkaido J. Dent. Sci.* **18** (1997) 85–104.
6. F. WATARI, A. YOKOYAMA, H. MATSUNO, F. SASO, M. UO and T. KAWASAKI, *Mater. Sci. Forum* **308–311** (1999) 356–361.
7. R. V. STUART, “Vacuum Technology, Thin Film and Sputtering” (Academic Press Inc., New York, 1983).
8. K. DE GROOT, J. G. C. WOLKE and J. A. JANSEN, “Proceedings of the Institute of Mechanical Engineers” Part H, **212** (1998) 137–147.
9. K. OZEKI, I. NISHIMURA and T. YUHTA, “Proceedings of the Symposium On Precision Engineering” Tokyo (1992) 977–978.
10. H. LEISTE, M. STÜBER, V. SCHIER and H. HOLLECK, *Mater. Sci. Forum* **308–311** (1999) 467–475.
11. P. BENJAMIN and C. WEAVER, “Proceedings of the Royal Society of London, Series A” **254** (1960) 163.
12. K. OZEKI, T. YUHTA, H. AOKI, I. NISHIMURA and Y. FUKUI, *Bio-Med. Mat. Eng.* **10** (2000) 221–227.
13. K. OZEKI, T. YUHTA, H. AOKI, I. NISHIMURA and Y. FUKUI, *Bio-Med. Mat. Eng.* **11** (2001) 63–68.
14. T. LI, J. LEE, T. KOBAYASHI and H. AOKI, *J. Mater. Sci.: Mater. Med.* **7** (1996) 355–357.

*Received 12 April
and accepted 25 September 2001*